

Series PSM  
 Slide Potentiometer  
 Molded Element  
 100,000 Cycle Life  
 Metal or Plastic Shaft Options  
 With/Without Dust Cover  
 RoHS Compliant



#### MODEL STYLE

Dual Gang	PSM
-----------	-----

#### ELECTRICAL<sup>1</sup>

Resistance Range, Ohms	500 -1M
Standard Resistance Tolerance	± 20%
Resistance Tapers	A,B,C
Residual Resistance	Terminals 1 to 2:Less than 10 ohms Terminals 2 to 3:Less than 30 ohms
Input Voltage, Maximum	Linear B taper: 200 Vac    Other tapers: 150 Vac
Power rating, Watts (Single Unit / Dual Unit)	<b>Linear B taper:</b> 20mm: 0.1W / 0.05W, 30mm: 0.2W / 0.1W 45mm: 0.25W / 0.125W, 60mm:0.2W / 0.2W  <b>Other tapers:</b> 20mm: 0.05W / 0.025W, 30mm: 0.1W / 0.05W 45mm: 0.125W / 0.06W, 60mm:0.1W / 0.1W
Dielectric Strength	300Vac, 1 minute
Insulation Resistance, Minimum	10M ohms at 250Vdc/ 1 minute
Sliding Noise	Less than 100mV
Gang Error	±3dB (-40dB to 0dB)

#### MECHANICAL

Static Stop Strength, Minimum	5.0 Kg/cm
Operating Force	10gf to 100gf
Detent Slip-out force	30gf to 200gf

#### DURABILITY

Sliding Life	100,000 cycles
--------------	----------------

<sup>1</sup> Specifications subject to change without notice.

# Series PSM

## ORDERING INFORMATION<sup>2</sup>

### Model PSM

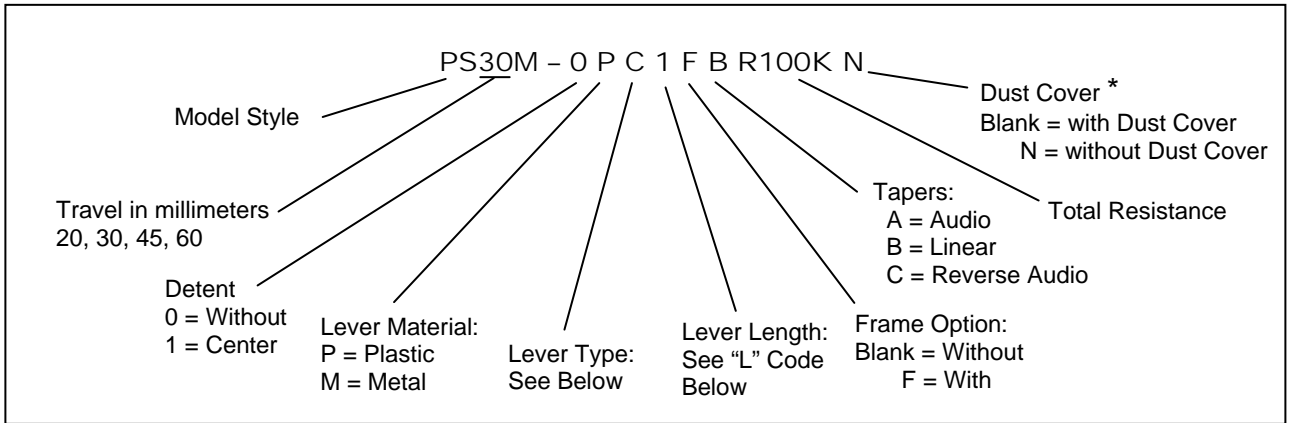

## STANDARD RESISTANCE VALUES, OHMS

500	1K	2K	5K	10K	20K	50K	100K	200K	500K	1 MEG
-----	----	----	----	-----	-----	-----	------	------	------	-------

## CIRCUIT DIAGRAM

### PSM (Dual gang)

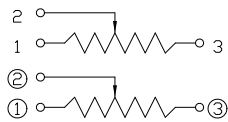

<sup>2</sup> Contact our customer service for custom designs and features.

# Series PSM

## Plastic Lever Types

E-Type		B-Type		C-Type		D-Type		
L	5.0	L	15	L	10 15	L	10 15 20	
CODE	1	CODE	1	CODE	1 2	CODE	1 2 3	

\* Dust Cover option not offered for levers less than 10 mm in length

## Metal Lever Types

D-Type				C-Type				E-Type		
L	15	20	25	F	5	10	10	10	L	7.6
CODE	1	2	3	CODE	1	2	3	4	CODE	1

\* Dust Cover option not offered for levers less than 10 mm in length

# Series PSM

## OUTLINE DRAWING

**With Dust Cover**

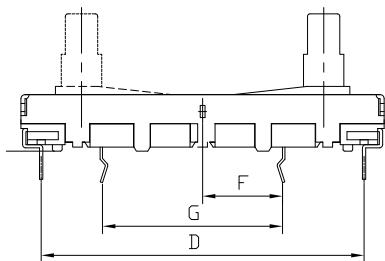
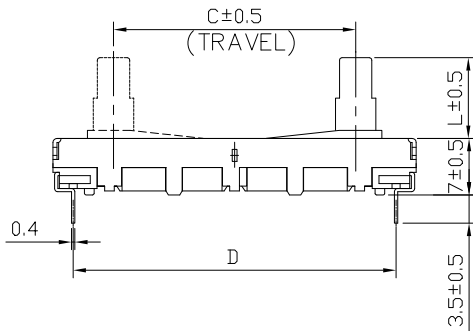
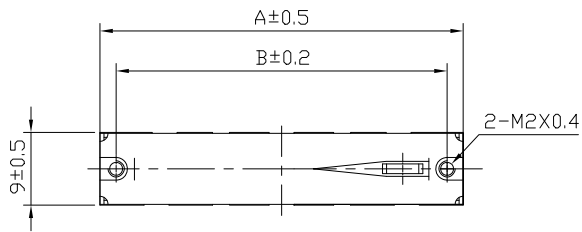

FRAME OPTION (F)

**Without Dust Cover**

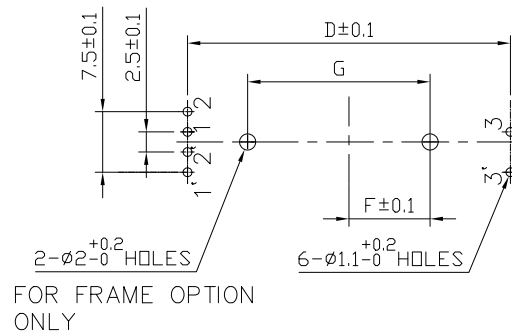
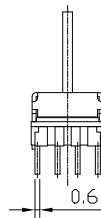
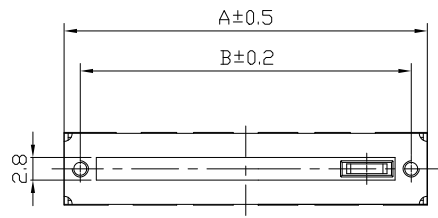

**PSM Dimensions:**

MODEL	A	B	C	D	F	G
PS20M	35	31	20	30	5	12.5
PS30M	45	41	30	40	10	22.5
PS45M	60	56	45	55	15	32.5
PS60M	75	71	60	70	22.5	47.5